

L-Band, GaN/SiC, RF Power Transistor

1.2 - 1.4 GHz | 720 W typ | 72% Efficiency typ | 12 dB Gain typ | 50 V | 300µs Pulse Length, 10% Duty Cycle

IGN1214M650A is a high power GaN-on-SiC RF power transistor that has been designed to suit the unique needs of modern radar systems. It supplies a minimum of 650 W of peak output power, with typically >12 dB of gain and 72% efficiency. It operates from a 50 V supply voltage. For optimal thermal efficiency, the transistor is housed in a metal-based package with an epoxy-sealed ceramic lid.



FEATURES

- GaN on SiC HEMT Technology
- Output Power >650 W
- Pre-matched Input & Output Impedance
- High Efficiency - 72% typical
- 100% RF Tested Under 300µs, 10% duty cycle pulse conditions
- RoHS and REACH Compliant

APPLICATIONS

- L-band Radar Systems

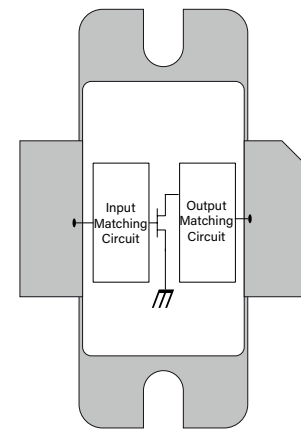

Table 1. RF Electrical Characteristics (Case temperature = 25 °C unless otherwise stated)

Parameter	Symbol	Min	Typ	Max	Units	Test Conditions
RF Output Power	$P_{OUT,RF}$	650	720	850	W	$P_{IN} = 40W$ $f = 1.2, 1.3, 1.4 \text{ GHz}$ 300µs pulse length 10% duty cycle pulse conditions $V_{DS} = 50V, I_{DQ} = 200mA$
Gain	G	12.1	12.6	13.3	dB	
Drain Efficiency	η	55	72	80	%	
Pulse Droop	D	-0.5	-0.1	+0.1	dB	
Input Return Loss	IRL	7	12	18	dB	
Load Mismatch Stability	VSWR-S	2:1				
VSWR Withstand	VSWR-LMT	3:1				

Note: Consult Integra Technologies Application Note 001 for information on how RF output power and pulse droop are measured.

Table 2. Absolute Maximum Ratings (Not Simultaneous)

Parameter	Symbol	Value	Units	Test Conditions
DC Drain-Source Voltage	V_{DS}	150	V	25 °C
DC Gate-Source Voltage	V_{GS}	-8 to +1	V	25 °C
DC Drain Current	I_D	72	A	25 °C
DC Gate Current	I_G	72	mA	25 °C
RF Input Power	P_{RFIN}	40	W	25 °C
Operating Channel Temperature	T_{CH}	-55 to +225	°C	
Storage Temperature	T_{STG}	-55 to +150	°C	

Note: Operation outside the limits given in this table may cause permanent damage to the transistor

Table 3. DC Electrical Characteristics (Case temperature = 25 °C unless otherwise stated)

Parameter	Symbol	Min	Typ	Max	Units	Test Conditions
Gate Pinch-Off Voltage	V_p	-5.0			V	$V_{DS} = 50V, I_{DS} = 1mA$
Quiescent Gate Voltage	V_Q		-2.5		V	$V_{DS} = 50V, I_{DQ} = 200mA$

Table 4. Test Fixture Source & Load Impedances (Case temperature = 25 °C unless otherwise stated)

Frequency (GHz)	Z_{IF}	Z_{OF}	Units	Test Conditions
1.2	2.8 - j1.2	2.0 - j1.8	Ω	$P_{OUT} = 650W$ 300 μs pulse length, 10% duty cycle $V_{DS} = 50V, I_{DQ} = 200mA$
1.3	2.7 - j0.7	2.0 - j1.6	Ω	
1.4	2.6 - j0.3	1.9 - j1.4	Ω	

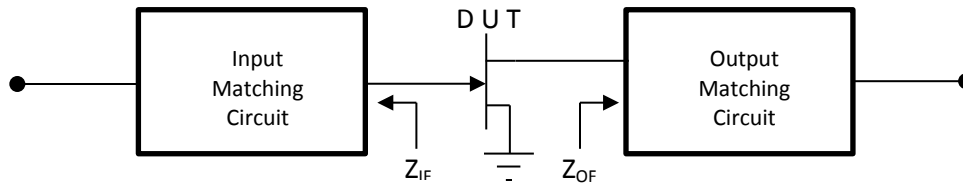
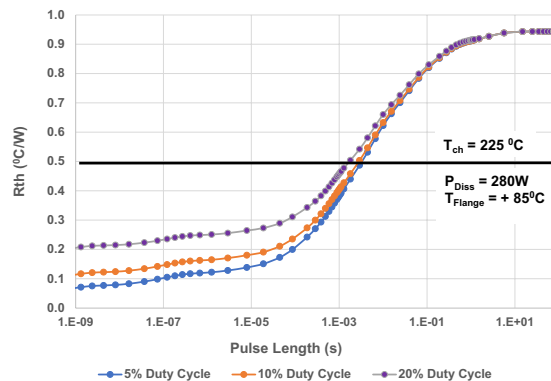

Table 5. Thermal Resistance (Case temperature = 85 °C unless otherwise stated)

Parameter	Symbol	Min	Typ	Max	Units	Test Conditions
Peak Thermal Resistance, Channel to Case	R_{TH}		0.3		°C/W	$P_{DISS} = 280W$ 300 μs pulse length, 10% duty cycle $V_{DS} = 50V$



TYPICAL PERFORMANCE

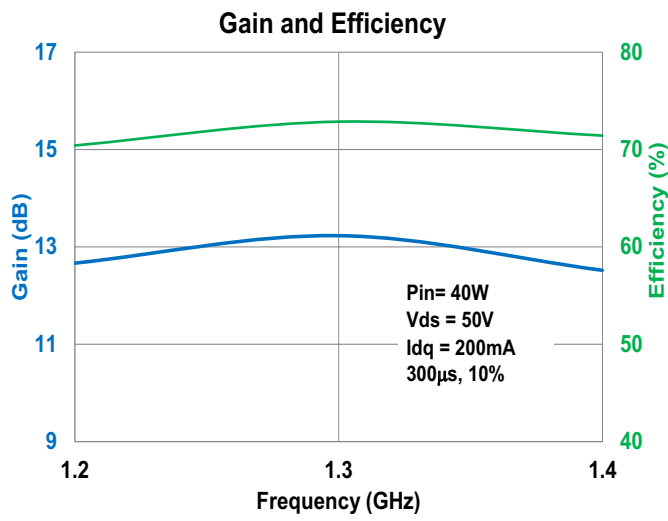

Figure 1

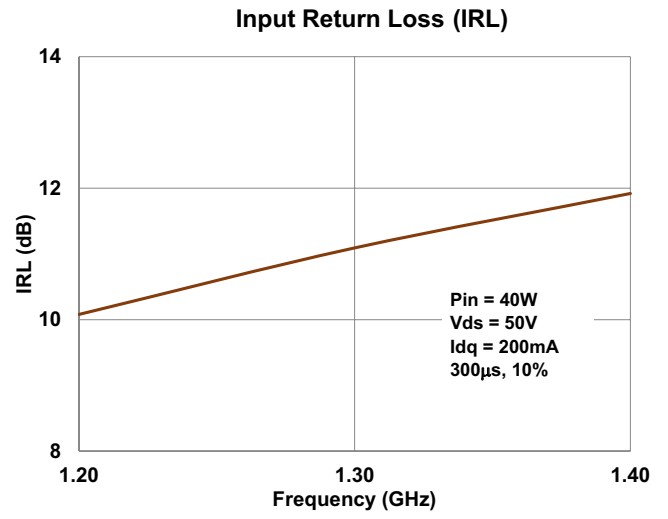
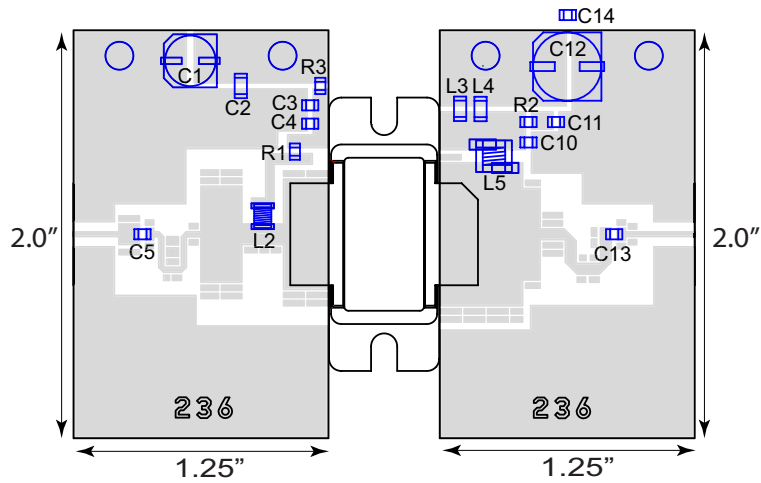

Figure 2

TEST FIXTURE



Bill of Materials for IGN1214M650A Test Fixture

Designator	Description	Quantity	Part Number
C1	CAP 47 μ F, 25V, Electrolytic	1	PCV1E470MCL2GS
C2	CAP 1 μ F, 100V, 1206, X7R	1	12061C104KAT2A
C3, C11	CAP 0.1 μ F, 0805, 100V, X7R	2	08051C104K4T2A
C4, C5, C10, C13	CAP 18pF, 0805	4	600F180JT250XT
C12	CAP 68 μ F, 63V, Electrolytic	1	EEE-FK1J680P
C14	CAP 4700 μ F, 63V, Electrolytic	1	UVR1J472MRD6
L2	IND 27.3nH, 0908	1	0908SQ-27N
L3, L4	IND 330OHM, 1206, 6A	2	BLM31PG330SN1L
L5	IND 18.5nH	1	A05TJL
R1, R2	RES, 10 OHM, 0805	2	ERJ-6ENF10R0V
R3	RES, 200 OHM, 0805	1	ERJ-6ENF2000V
PC Board Type	ROGERS RT6010.2, 25mil, 1/1oz. Copper	2	

PACKAGE PL95A1

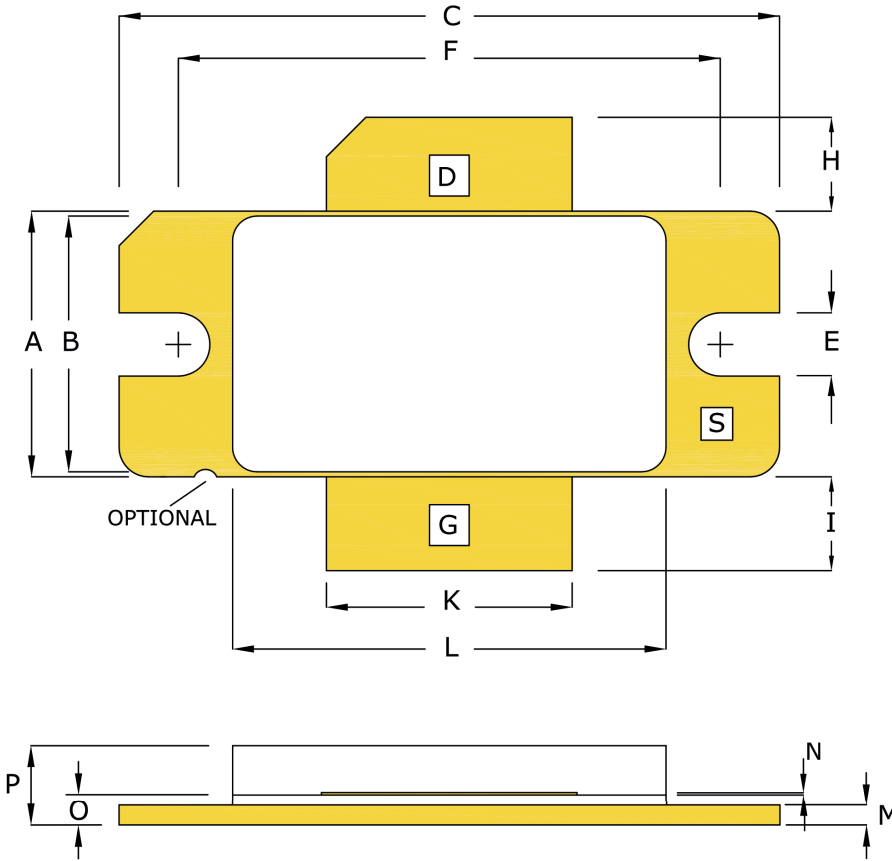

DIM	INCHES		MILLIMETERS	
	MIN	MAX	MIN	MAX
A	0.537	0.543	13.64	13.79
B	0.515	0.525	13.08	13.34
C	1.337	1.343	33.96	34.11
E	0.123	0.133	3.12	3.38
F	1.095	1.105	27.81	28.07
H	0.175	0.205	4.45	5.21
I	0.175	0.205	4.45	5.21
J	--	--	--	--
K	0.495	0.505	12.57	12.83
L	0.871	0.889	22.12	22.58
M	0.036	0.044	0.91	1.12
N	0.003	0.006	0.08	0.15
O	0.059	0.065	1.50	1.65
P	0.154	0.182	3.91	4.62

PIN SCHEDULE	
D	DRAIN
S	SOURCE
G	GATE

ESD & MSL Rating

Parameter	Rating	Standard
ESD Human Body Model (HBM)	TBD	ESDA/JEDEC JS-001-2012
ESD Charged Device Model (CDM)	TBD	JEDEC JESD22-C101F
Moisture Sensitivity Level (MSL)	Unlimited Shelf Life	IPC/JEDEC J-STD-020

RoHS Compliance

Integra Technologies, Inc declares that its GaN and LDMOS Transistor Products comply with EU Directive 2011/65/EU on the restriction of the use of certain hazardous substances in electrical and electronic equipment (RoHS2), as adopted by EU member states on January 2, 2013 and amended on March 31, 2015 by EU Directive 2015/863/EU.

REACH Compliance

Integra Technologies supports EU Regulation number 1907/2006 concerning the Registration, Evaluation, Authorization, and Restriction of Chemicals (REACH) as these apply to Integra semiconductor products, development tools, and shipping packaging.

In support of the REACH regulation, Integra will:

- Inform customers and recipients of Integra product if they contain any substances that are of very high concern (SVHC) per the European Chemical Agency (ECHA) website.
- Notify ECHA if any Integra product that contains any SVHCs which exceed guidelines for REACH chemicals by weight per part number and for total content weight per year for all products produced in or imported to the European market.
- Cease shipments of product containing REACH Annex XIV substances until authorization has been obtained.
- Cease shipment of product containing REACH Annex XVII chemicals when restrictions apply.

Integra has evaluated its materials, BOMs, and product specifications and product and has determined that this transistor conforms to all REACH and SVHC regulations and guidelines. Integra has implemented actions and control programs that will assure continued compliance.

Disclaimer

Integra Technologies Inc. reserves the right to make changes without further notice to any products herein. Integra Technologies Inc. makes no warranty, representation or guarantee regarding the suitability of its products for any particular purpose, nor does Integra Technologies Inc. assume any liability arising out of the application or use of any product or circuit, and specifically disclaims any and all liability, including without limitation consequential or incidental damages. Integra Technologies Inc. products are not designed for use in life support appliances, devices, or systems where malfunction of these products can reasonably be expected to result in personal injury. Integra Technologies Inc. customers using or selling these products for use in such applications do so at their own risk and agree to fully indemnify Integra Technologies Inc. for any damages resulting from such improper use or sale.

DEFINITIONS:

DATA SHEET STATUS

Advanced Specification - This data sheet contains Advanced specifications.

Preliminary Specification - This data sheet contains specifications based on preliminary measurements and data.

Final Specification - This data sheet contains final product specifications.

MAXIMUM RATINGS Stress above one or more of the maximum ratings may cause permanent damage to the device. These are maximum ratings only operation of the device at these or at any other conditions above those given in the characteristics sections of the specification is not implied. Exposure to maximum values for extended periods of time may affect device reliability.

Integra Technologies, 321 Coral Circle, El Segundo, CA 90245-4620 | Phone: 310-606-0855 | Fax: 310-606-0865